

CURRENT TRENDS OF HIGH-VACUUM PUMPS

K.E. Demikhov

Bauman Moscow State Technical University, Moscow, Russian Federation
e-mail: ked@bmstu.ru

Turbomolecular vacuum pumps are widely used in various fields of science and technology, which continually stimulates the interest in creating new kinds of pumps. The theory of operating process in the flow channel of turbomolecular vacuum pumps under various operating conditions is developed; one of its key features is a fairly accurate estimation of their main parameters and characteristics, thereby various influencing factors can be analyzed. Thus, the flow channel of a single high-vacuum pump could be optimized by various optimization criteria. An extensive database is accumulated enabling scientists to develop efficient turbomolecular vacuum pumps with various initial parameters. Consequently, a relevant issue today is the search for perspectives for turbomolecular vacuum pumps further development. The paper considers current trends in designing the improvement of turbomolecular vacuum pumps with hybrid flow channels. Advantages of certain designs are specified. The guidelines for their applications are given. The results of the comparative analysis are presented, which show an application efficiency of various flow channel design arrangements.

Keywords: flow channel, rotor wheel, agility, pumping parameters, ultimate vacuum.

From the moment of their appearance (1960-s), vacuum turbomolecular pumps (TMP) have occupied an important position among other high-vacuum pumping devices. Due to a number of their significant advantages, TMP posed a serious threat to the recognized leaders in vacuum pumping systems, such as oil-vapour vacuum pumps, which cannot be referred to as oil-free pumping systems (not “polluting” the volume with organic compounds). All of these make TMP the focus of attention for researchers from different countries. This resulted in a number of research papers devoted to the processes occurring in the TMP flow channel [1, 2].

At present, it can be justifiably stated that TMP are ones of few high-vacuum pumps that have adequate theoretical scientific support for developing state-of-art pumps without any subsequent experimental testing and refinement.

BMSTU researchers have made a significant contribution to this field, which leads to software for upgrading the flow channel of high-vacuum mechanical pumps (HVMP) [3]. It founded the basis for the first of its kind HVMP CAD system created in close cooperation with the Special Design and Engineering Bureau *Vector*. No analogous system has appeared in the field of vacuum engineering until now.

The system being put into operation in 1985 allowed developing and launching the manufacturing production of a whole range of the



Fig. 1. Russian HVMP developed in cooperation with BMSTU

optimized HVMP: TMNG-450 (TMHG-450), TMNG-500 (TMHG-500), TMNG-600XC (TMHG-600XC) (chemically stable modification), TMNG-1000 (TMHG-1000), and TMNG-100 (TMHG-100) over only two years period (Fig. 1).

TMNG-100 pump deserves special attention. This is the world's only absolutely superclean HVMP with the atmospheric pumping pressure. This pump is unique at present.

HVMP calculation programs developed at BMSTU enable multiparametric and multicriterial optimization of their features and characteristics, which results in a significant scope for designing efficient and up-to-date HVMPs [3]. This also allows the designers to fulfil the pumps potential.

At present, researchers are focusing particularly on formalizing the structural optimization of objects being designed. Unfortunately, this problem is currently too complex to be solved in the case of HVMP.

The conceptual foundation developed at BMSTU suggests selecting the perspective flow channel layouts according to a number of some main trends [3]. One of these trends considering the HVMP flow channel structure aims at improving the pump rotor wheels.

The following TVMP design was suggested in [3] (Fig. 2, *a*): the rotor wheels with two-tier passages are placed on the pressure side of the flow channel with mirror-image inclined passages. It directs the gas flow in the desired way (see Fig. 2, *a*). There are open-end holes in the wheel hub to divert the gas on the pressure side. In spite of the certain technical difficulties, it should be noted that the pump dimensions are reduced while fulfilling the requirements for the increased pressure conditions. The flow channel construction with the inclined frontal radial blades is designed for the same purpose (Fig. 2, *b*). It enables radial gas to flow alternately to the axis and away from it. This leads to increasing the pressure by some extended channels within the reduced TMP flow channel.

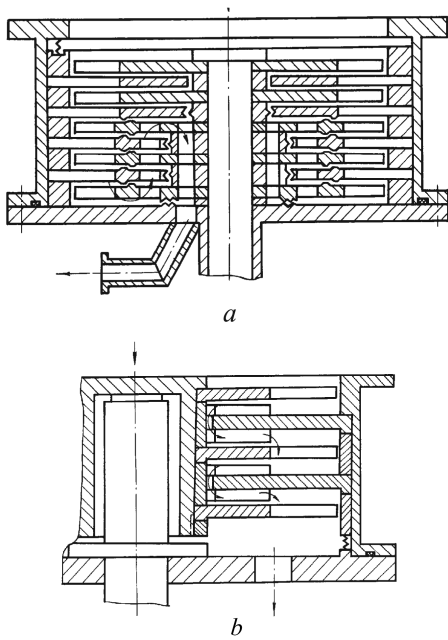

Fig. 2. TMP structural scheme with gas reversing (*a*) and frontal radial blade on stator wheels (*b*)

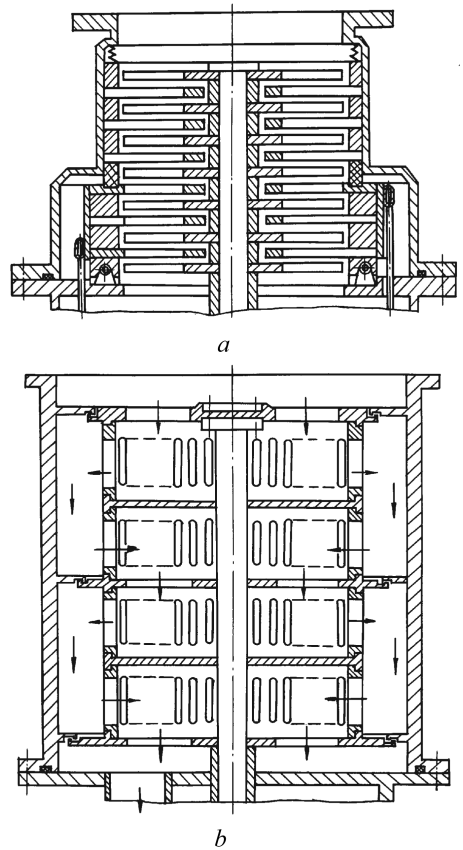

Fig. 3. HVMP design arrangements with adsorption pumps on the pressure side (*a*) and axial and radial gas flow in the rotor (*b*)

Another perspective trend of HVMP improvement consists of combining TVP elements with other types of high-vacuum pumps based on different operating principles in the flow channel.

A TMP design arrangement (Fig. 3, *a*) was suggested with an adsorbent located in special cavities of the exit stator wheels. This enables additional gas evacuation in these wheels. To increase the gas absorption efficiency, these wheels (located on the pressure side) are cooled up to 80...100 K with liquid nitrogen fed into a special cooling jacket in a special vacuum chamber. This flow channel arrangement eliminates the need to use oil fore pumps for the initial vacuum when putting the pump into operation with the help of the atmospheric pressure, as this function will be performed by an adsorbent. Moreover, the adsorbent regeneration will be realized without stopping the TMP and disengaging it from the pumping system.

It is known that TMP should not be used for gas media containing solid macro particles without special protection since it results in the degradation of pump parameters.



Рис. 4. TMP design arrangement with a hybrid flow channel

TMPs with a variable flow and without stator wheels have been designed. This allows pumping gases with solid macro particles. It is very important for various sputtering units. One of the pump modifications is shown in Fig. 3, *b*. A peculiar feature of this design is a combination of rotor wheels with alternating axial and radial gas flows in the pump flow channel. As a result, the efficiency of each stage is increased.

TMP dimensions can be reduced if the rotor wheels with a radial gas flow are positioned on the pressure side (Fig. 4).

The research demonstrates that this design arrangement has significant possibilities, especially with the multi parametric optimization of TMP main characteristics.

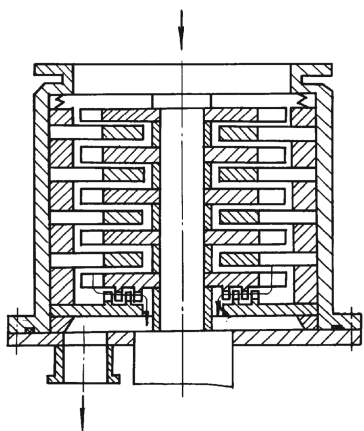
The pressures ratio can be increased without increasing the pump dimensions, if TMP axial stages and a cylindrical molecular vacuum pump (MVP) unit are coupled in the flow channel.

In Fig. 5 TMNG-500 (variant 1) and TMNG-450 (variant 2) are presented in comparison. TMNG-500 flow channel contains a conventional set of both the axial rotor and stator blade wheels; in TMNG-450 it contains blocks of the axial blade wheels and a cylindrical molecular pump with helical channels in the pump casing. The shaft of these pumps is mounted onto two radial and one axial aerostatic bearings.

TMNG-500 development was determined by the need to verify the data for the efficiency of the hybrid flow channel designs and to estimate manufacturing hours compared to TMN-450 pump, the flow channel of which contains both the axial stages and molecular stages unit.

After comparing the mass produced vehicles it was established that with 25% increase in the agility reference value, both the volume and mass of TMNG-500 pump grow by 20% and 6%, correspondingly compared to TMNG-450 pump. Apart from that, according to the Special Design and Engineering bureau *Vector* the production costs of these models include 862 (TMNG-500) and 950 (TMNG-450) standard hours, correspondingly. All of this testifies to the superiority of the hybrid flow channel pumps, as they possess the improved dimensional characteristics accounting for a certain complexity in manufacturing. This is also confirmed by the sustained trend of the world's leading manufacturers to increase the number of vacuum TMP with the hybrid flow channel (with the axial and molecular stages) [4–8].

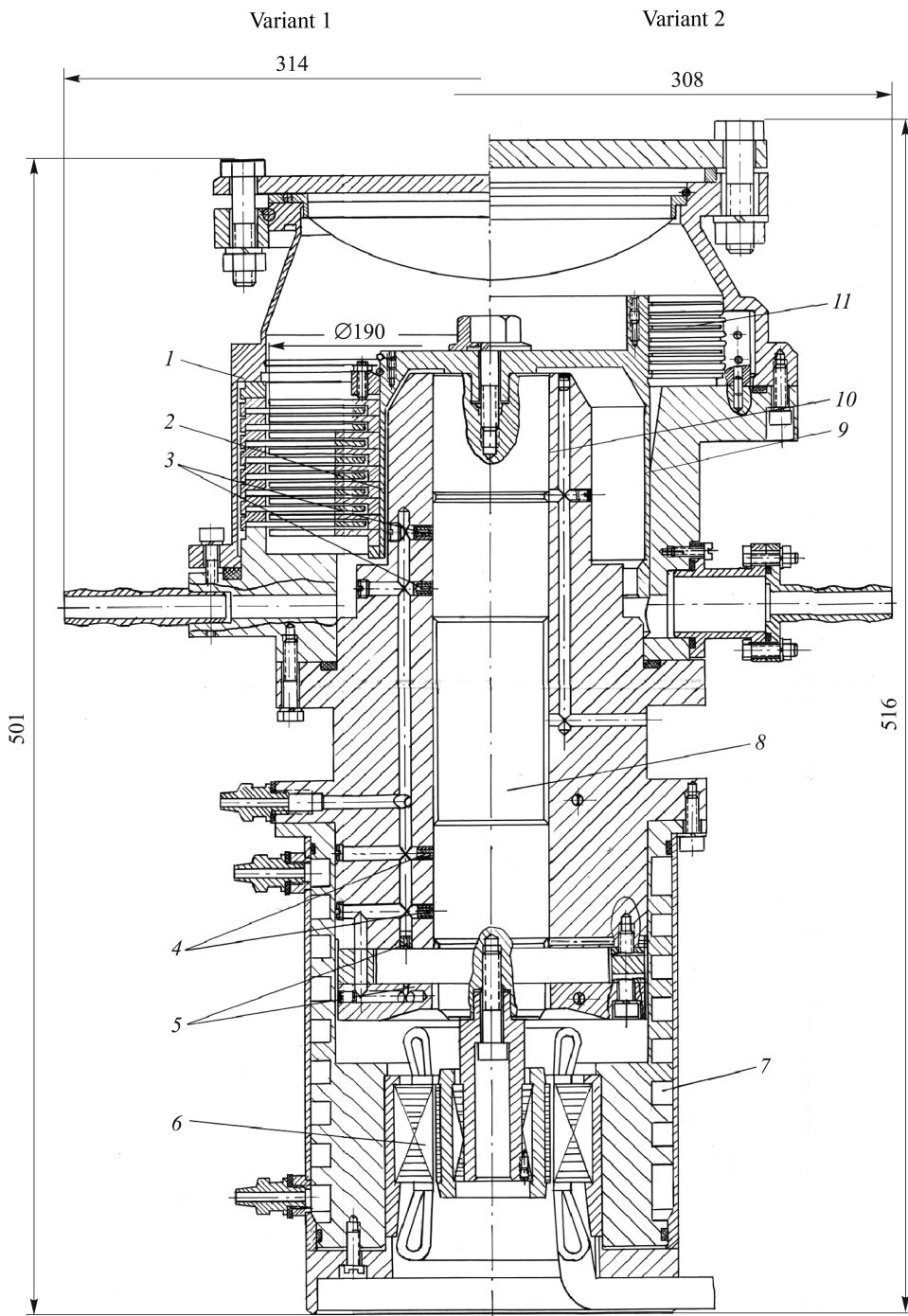

Fig. 5. HVMP general arrangement view

In order to analyze the effectiveness of using various flow channel design arrangements along with optimization of their main parameters and characteristics, we calculate a range of pumps with the agility S_H for

nitrogen and hydrogen 1.5; 3.5; 50; 10; 20 m³/s. The suction pressure for nitrogen is $p = 1 \cdot 10^{-6}$ Pa, for hydrogen it is $p = 1 \cdot 10^{-5}$ Pa, and the forevacuum pressure is $p_f = 0.1$ Pa. The calculation results are given in the table.

The following characteristics were selected as the controlled parameters: the blades angle α , the channels relative width a/b , the channels relative height λ . Flow channel optimization calculation was performed for optimality criteria: the volume V_{fch} and flow channel mass M .

The following design arrangements were analyzed (see Table): the conventional flow channel with an axial flow (1), the flow channel with

Comparing optimal parameters for different design variants of VMP flow channels

$S_H, \text{m}^3/\text{s}$	Gas	Design	$N_{0c}/N_{a(m)}$	$V_{fch}, \text{m} \cdot 10^3$	M, kg
1.5	N ₂	1	15/-	6.9	8.9
		2	9/13	4.4	4.8
		3	9/13	5.6	5.3
	H ₂	1	46/-	23	30.8
		2	35/19	18	22.4
		3	27/26	17	16.7
3.5	N ₂	1	14/-	15	19.3
		2	9/10	10	11.4
		3	9/11	15.3	13.7
	H ₂	1	45/-	53	70.4
		2	33/18	39.6	49.1
		3	27/25	47.3	40.8
5	N ₂	1	13/-	39.7	54.4
		2	7/13	22	26.0
		3	8/11	32.5	34.5
	H ₂	1	44/-	148	206.0
		2	34/20	110	142.0
		3	25/28	109	105.8
10	N ₂	1	11/-	110	157.1
		2	7/8	73	90.9
		3	7/10	85	89.6
	H ₂	1	36/-	380	529.9
		2	26/18	270	359.0
		3	21/25	255	267.0
20	N ₂	1	11/-	230	314.4
		2	7/7	145	181.0
		3	7/10	181	195.7
	H ₂	1	36/-	755	1066.4
		2	23/24	487	623.0
		3	21/24	500	557.0

axial stages on the suction side, the radial flow stages (from the periphery to the center) on the pressure side (2); the flow channel combining axial stages (suction) and molecular stages (pressure) (3).

After comparing the computational data, it becomes apparent that the hybrid flow channel arrangements provide sufficient advantage according to different optimality criteria. Thus, the flow channel volume decreased 1.3 to 1.8 times depending on both the agility and type of the gas being pumped, while the flow channel mass decreased 1.7 to 2 times.

The gains in the flow channel volume was in most cases higher for the arrangement of axial and drum stages (variant 2). When the flow channel mass was selected as the optimality criterion, the arrangement of axial and molecular stages (variant 3) appeared more preferable, especially with hydrogen as actuation gas.

Thus, the usage of the original software for designing the state-of-art TMPs increases their efficiency by optimization of their main characteristics and parameters. Another perspective trend for TMP improvement is creating and applying new design arrangements of the flow channel accounting for the operational conditions and feasibility of the appropriate manufacturing technology. Potentially, the fundamentals of full structural optimization can be formalized for the modern TMP design process.

REFERENCES

- [1] Hoffman D.M., Singh B., John H. Thomas III, eds. Handbook of Vacuum Science and Technology Academic Press, 1997 . 835 p. (Russ. Ed.: Khoffman D. (red.), Singkh B. (red.), Dzh. Tomas III (red.) Spravochnik po vakuumnoy tekhnike i tekhnologiyam. Moscow, Tekhnosfera Publ., 2011. 736 p.).
- [2] Demihov K.E., Panfilov Yu.V., Nikulin N.K. Avtonomova I.V., Aleksandrova A.T., Androsov A.V., Burmistrov V.A., Bykov D.V., Deulin E.A., Ivanovskij G.F., Isaev A.V., Kalinkin D.A., Kapustin E.N., Kemenov V.N., Kuprijanov V.I., eds. Vakuumnaja tehnika: Spravochnik [Handbook of vacuum technology]. 3rd Ed. Moscow, Mashinostroenie Publ., 2009. 590 p.
- [3] Demikhov K.E., Nikulin N.K. Optimizatsiya vysokovakuumnykh mekhanicheskikh nasosov [Optimization of high-vacuum mechanical pumps]. Moscow, MG TU im. N.E. Bauman Publ., 2010. 255 p.
- [4] Product Leitfaden [Product Guide]. Alcatel Hochvakuumtechnik GmbH, Annecy, 1995.
- [5] Komponenten für die Vakuumtechnik [Components for vacuum technology]. Balzers-Pfeiffer GmbH, Balzers, 1996.
- [6] Vakuum katalog [Vacuum catalog]. Edwards Hochvakuum GmbH, Marburg, 1993.
- [7] Katalog HV 300, Teil B [Catalog HV 300, Part B]. Leybold AG, Cologne, 1994.
- [8] Vacuum products catalog. Varian Ass. Inc., Lexington, 1995–1998.

The original manuscript was received by the editors in 10.06.2014

Demikhov K.E. — D.Sc. (Eng.), Professor, Head of the Department of Vacuum and Compressor Units, Bauman Moscow State Technical University, Honoured Scientist of the Russian Federation, author of over 170 scientific publications in the field of vacuum machine building.

Bauman Moscow State Technical University, ul. 2-ya Baumanskaya 5, Moscow, 105005 Russian Federation.

The translation of this article from Russian into English is done by I.R. Shafikova, a senior lecturer, Linguistics Department, Bauman Moscow State Technical University under the general editorship of N.N. Nikolaeva, Ph.D. (Philol.), Associate Professor, Linguistics Department, Bauman Moscow State Technical University.